

GENERAL DIMENSIONS

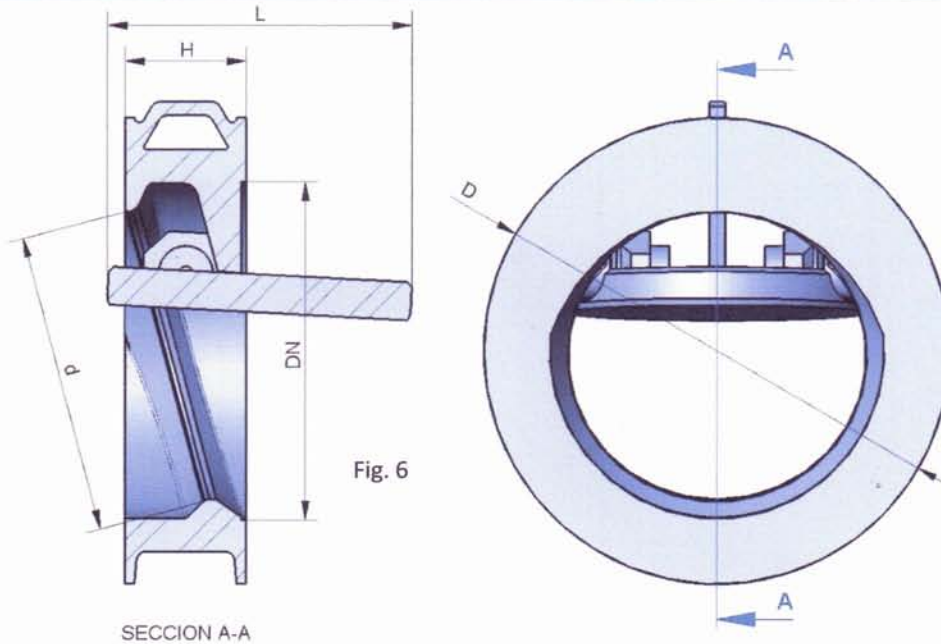

Materials:

Body/Disc: CF8M (316)

Stem: AISI 316

Seat: metal-metal

DN	D								d	H	L	Weight
	PN6	PN10	PN16	PN25	PN40	PN64	ASA150	ASA300				
40	87	94	94	94	94	103	73	73	34	33	45	--
50	97	107	107	107	107	113	92	92	44	43	60	1,5
65	117	127	127	127	127	138	104	104	58	46	70	2,6
80	132	142	142	142	142	148	128	128	72	64	90	3,7
100	152	162	162	162	162	174	157	157	90	64	102	4,6
125	182	194	194	194	194	211	185	185	112	70	120	8
150	207	219	219	224	224	248	213	213	135	76	140	10
200	262	273	273	284	291	310	270	270	180	89	185	18
250	317	329	329	340	352	365	323	323	225	114	220	24
300	373	378	384	401	418	425	381	381	270	114	262	38
350	423	438	444	458	475	487	412	412	315	127	310	48
400	473	490	496	515	547	544	470	470	365	140	360	66
450	528	539	556	565	560	580	533	533	420	152	400	93
500	578	594	618	625	629	615	584	584	460	152	450	115
600	679	696	735	732	735	735	692	692	555	178	535	180
700	784	811	805	834	840	840	800	800	650	229	620	260
800	891	918	912	943	960	960	914	914	740	241	715	390
900	991	1018	1012	1043	1070	1070	1022	1022	835	275	800	--
1000	1080	1120	1126	1152	1180	1180	1123	1123	945	300	925	--
1200	1295	1330	1330	1350	1380	1380	1358	1358	1140	350	1147	--

Table 2

WITH DAMPER AND COUNTERWEIGHT

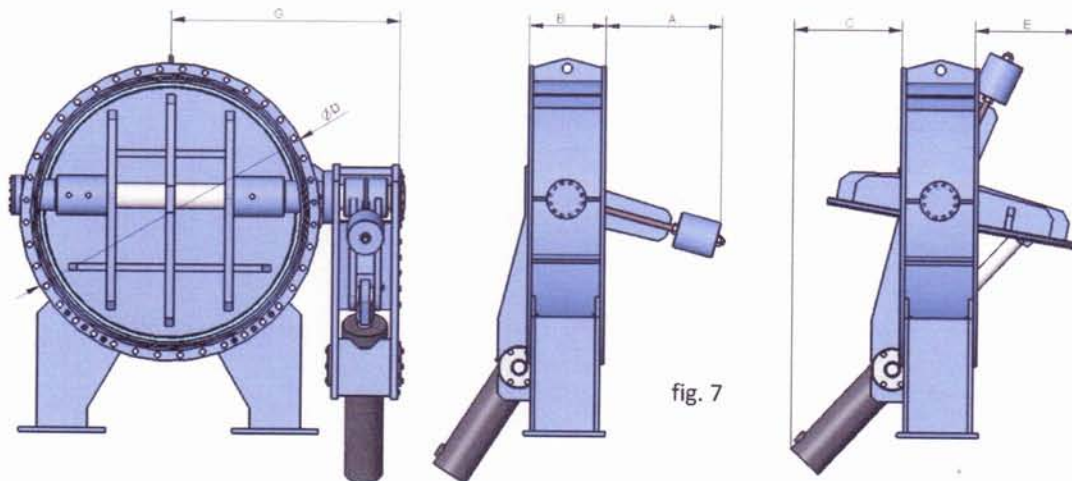

fig. 7

- For more DN's consult CMO.

DN	D								A	B	C	E	G
	PN6	PN10	PN16	PN25	PN40	PN64	ASA150	ASA300					
50	97	107	107	107	107	113	92	92	13,1	43	170	17	53,5
65	117	127	127	127	127	138	104	104	22,4	46	170	24	63,5
80	132	142	142	142	142	148	128	128	24,7	64	177	26	71
100	152	162	162	162	162	174	157	157	39,4	64	103	38	81
125	182	194	194	194	194	211	185	185	52,8	70	103	50	97
150	207	219	219	224	224	248	213	213	210	76	274	64	284
200	262	273	273	284	291	310	270	270	238	89	265	96	309
250	317	329	329	340	352	365	323	323	225	114	265	106	336
300	373	378	384	401	418	425	381	381	225	114	270	148	330
350	423	438	444	458	475	487	412	412	218	127	329	183	413
400	473	490	496	515	547	544	470	470	216	140	334	220	453
500	578	594	618	625	629	615	584	584	472	152	405	262	543
600	679	696	735	732	735	735	692	692	456	178	392	319	609
700	784	811	805	834	840	840	800	800	485	229	345	380	659
800	891	918	912	943	960	960	914	914	500	241	607	474	710
900	991	1018	1012	1043	1070	1070	1022	1022	520	275	640	525	760
1000	1080	1120	1126	1152	1180	1180	1123	1123	550	300	685	605	800
1200	1295	1330	1330	1350	1380	1380	1358	1358	804	350	659	581	1104
1600	1710	1760	1750	1780	1815	--	--	--	744	470	790	853	1347

Table 3

COMPONENTS LIST

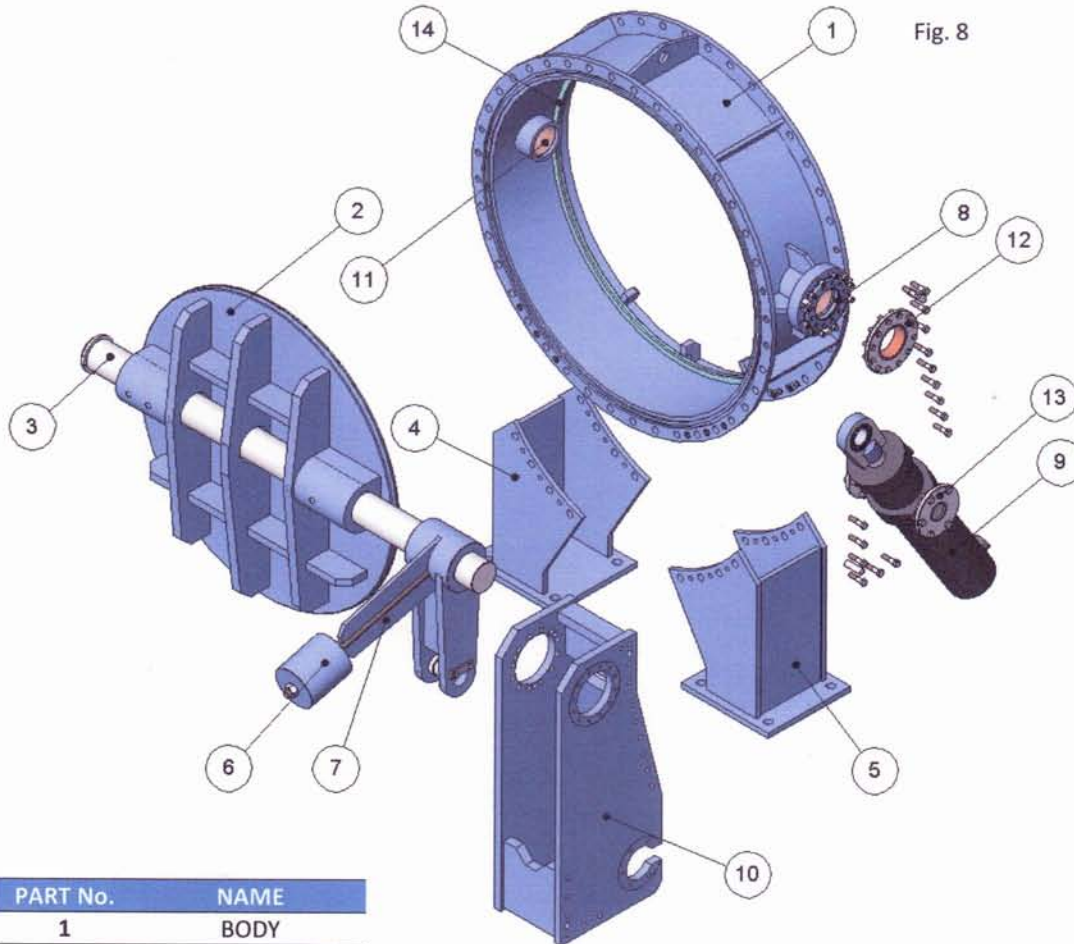

PART No.	NAME
1	BODY
2	FLAP GATE
3	STEM
4	BASE 1 (optional)
5	BASE 2 (optional)
6	COUNTERWEIGHT
7	LEVER
8	SEAL
9	DAMPER
10	SUPPORT
11	SOCKET
12	FLANGE
13	FLANGE COVER
14	SEAT

table 4