

G-3N TYPE **STAINLESS STEEL AISI 316** (Din 1.4408)
CARBON STEEL S-45C (Din 1.1191)
SIZE: 1/4" ~ 4"

FEATURES: * Pipe thread in accordance with ANSI B2.1, BS 21 1973, DIN 259/2999
* Locking device, Lug body.

- * Blow-out proof stem/Full port
- * Investment casting body and cap
- * 1000 PSI (69 BAR) W.O.G./1500 PSI (103 BAR) W.O.G.
- * Material: ASTM-A351-CF8M, ASTM-A351-CF8 & ASTM-A216-WCB

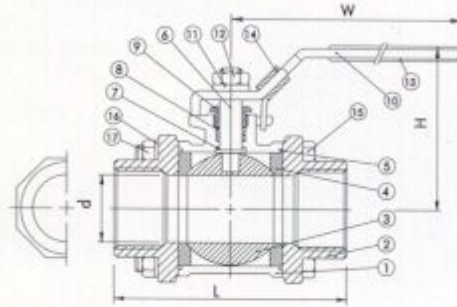

ITEM	PARTS	QTY	MATERIALS	
			G3N	G3N-C
1	BODY	1	ASTM-A351-CF8M	ASTM-A216-WCB
2	CAP	2	ASTM-A351-CF8M	ASTM-A216-WCB
3	BALL	1	ASTM-A351-CF8M	ASTM-A351-CF8M
4	BALL SEAT	2	15% R-PTFE	15% R-PTFE
5	JOINT GASKET	2	15% R-PTFE	15% R-PTFE
6	STEM	1	AISI 316	AISI 316
7	THRUST WASHER	1	PTFE	PTFE
8	STEM PACKING	2	PTFE	PTFE
9	GLAND NUT	1	AISI 304	AISI 304
10	HANDLE	1	AISI 304	AISI 304
11	STEM WASHER	1	AISI 304	AISI 304
12	STEM NUT	1	AISI 304	AISI 304
13	PLASTIC COVER	1	PLASTIC	PLASTIC
14	LOCK DEVICE	1	AISI 304	AISI 304
15	BOLT	4(4x6 SET)	AISI 304	AISI 304
16	SPRING WASHER	4(4x6 SET)	AISI 304	AISI 304
17	HEX NUT	4(4x6 SET)	AISI 304	AISI 304

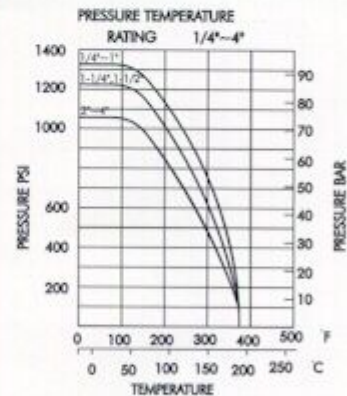

NOMINAL SIZE	d	L	H	W	B	D	S	Cv FACTOR	TORQUE kgf-cm	kgs
1/4"	11.6	59	51	105	12	18	14.1	6.6	40	0.40
3/8"	12.7	59	51	105	14	18	17.6	7.9	40	0.40
1/2"	15	64	55	125	17.1	22	21.7	11.2	54	0.58
3/4"	20	75	59	125	22.5	27.5	27.1	21	74	0.75
1"	25	86	73	160	28	33.5	33.8	34	104	1.08
1-1/4"	32	99	78	160	33.5	44	42.6	57	135	1.85
1-1/2"	38	113	91	190	43	50	48.7	80	180	2.60
2"	50	132	99	190	53	61.5	61.1	148	250	3.94
2-1/2"	65	180	130	245	65	76	76.9	265	480	8.06
3"	80	206	142	245	80	92	89.8	415	750	13.35
4"	100	261	174	325	100	115	115.4	780	1100	24.55