

G-2IN TYPE
SIZE: 1/4" ~ 3"

INVESTMENT CASTING, SCREWED ENDS
2-PC STAINLESS STEEL
BALL VALVE

- FEATURES:**
- * Pipe thread in accordance with ANSI B2.1, BS 21 1973, DIN 259/2999
 - * 800 PSI (55 BAR) W.O.G./1000PSI (69 BAR) W.O.G.
 - * Blow-out proof stem/Full port
 - * Investment casting body and cap
 - * Material: ASTM-A351-CF8M, ASTM-A351-CF8

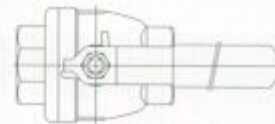
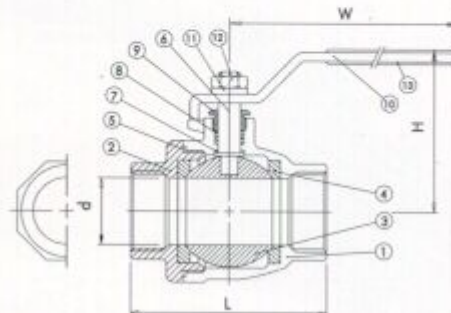

ITEM	PARTS	QTY	MATERIALS	
			G2IN	G2IN-C
1	BODY	1	ASTM-A351-CF8M	ASTM-A216-WCB
2	CAP	1	ASTM-A351-CF8M	ASTM-A216-WCB
3	BALL	1	ASTM-A351-CF8M	ASTM-A351-CF8M
4	BALL SEAT	2	15% R-PTFE	15% R-PTFE
5	JOINT GASKET	1	PTFE	PTFE
6	STEM	1	AISI 316	AISI 316
7	THRUST WASHER	1	PTFE	PTFE
8	STEM PACKING	2	PTFE	PTFE
9	GLAND NUT	1	AISI 304	AISI 304
10	HANDLE	1	AISI 304	AISI 304
11	SPRING WASHER	1	AISI 304	AISI 304
12	STEM NUT	1	AISI 304	AISI 304
13	PLASTIC COVER	1	PLASTIC	PLASTIC

NOMINAL SIZE	d	L	H	W	Cv FACTOR	TORQUE kgf-cm	kgs
1/4"	11.6	49	51	105	6.6	40	0.21
3/8"	12.7	49	51	105	7.9	40	0.21
1/2"	15	57	53	105	11.2	54	0.32
3/4"	20	65	59	125	21	74	0.51
1"	25	78	73	160	35	104	0.84
1-1/4"	32	90.5	78	160	57	135	1.34
1-1/2"	38	105	91	190	80	180	2.00
2"	50	127	99	190	148	250	3.47
2-1/2"	65	158	130	245	265	480	5.80
3"	80	185	142	245	415	750	9.51

